

14. May 2021

---

## condensate trap type 136.2, 1 1/2" x DN 40

---

Product No.       **026217**  
EAN:               4001636026217  
Discount group:    1

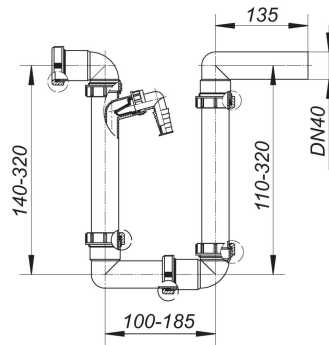

---

conforming to DIN 19541  
for the installation of air-conditioners, heating equipment, etc. Suitable for positive and negative pressure up to 2800 Pa (Pascal), transparent inlet tube, in case of water deficiency, may be filled through the hose connector

specification:

- swivel joints for flexible mounting
- hose connector with anti-reflux valve

material:

polypropylene